

Front Elevation

Side Elevation

Ledger Detail

TABLE "A"

Rafter Spans
(Df#2 or Better)

SIZE	SPACING	SPAN
2 x 4	12" O.C.	9' - 3"
	16" O.C.	8' - 5"
	24" O.C.	7' - 4"
	32" O.C.	*6' - 3"
2 x 6	12" O.C.	14' - 6"
	16" O.C.	13' - 2"
	24" O.C.	11' - 3"
	32" O.C.	*9' - 7"
2 x 8	12" O.C.	**19' - 2"
	16" O.C.	16' - 8"
	24" O.C.	14' - 7"
	32" O.C.	*12' - 8"
2 x 10	12" O.C.	**20' - 0"
	16" O.C.	**20' - 0"
	24" O.C.	17' - 10"
	32" O.C.	*16' - 2"
4 x 4	24" O.C.	9' - 9"
	32" O.C.	*9' - 3"
	48" O.C.	*7' - 8"
4 x 6	24" O.C.	15' - 4"
	32" O.C.	*13' - 9"
	48" O.C.	*11' - 3"
4 x 8	24" O.C.	**20' - 0"
	32" O.C.	*18' - 2"
	48" O.C.	*14' - 10"

TABLE "B"

Header Size & Spans
(Df#2 or Better)

RAFTER SPAN	HEADER SPAN	HEADER SIZE	FOOTING SIZE
Up to 12'	8'	4 x 6	18"
	10'	4 x 8	20"
	12'	4 x 10	22"
	14'	4 x 12	23"
12' to 20'	8'	4 x 8	22"
	10'	4 x 10	24"
	12'	4 x 12	26"
	14'	4 x 14	28"

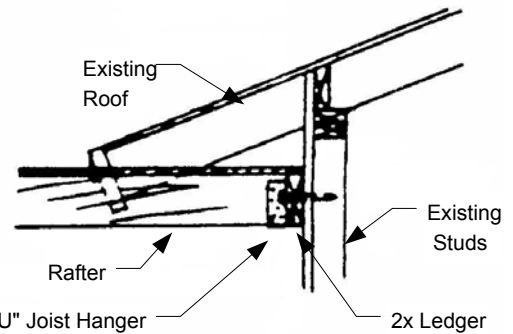

Use a continuous 2x ledger, same depth as the rafters, with 3/8" dia. x 5" lag bolts to each stud (16" O.C.). When the rafter span is greater than or equal to 14'-0", use 1/2" dia. x 5" lag bolts.

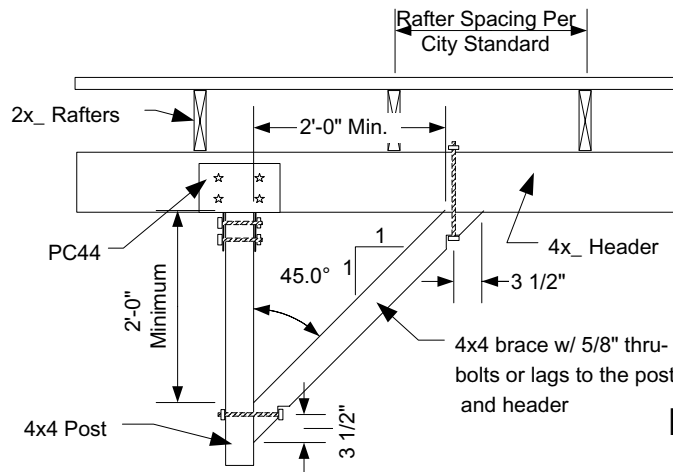

**Standard
(Required)
Bracing Detail**

* This spacing & span is for Lattice Covering Only!
 ** Limit dictated by the Header Design (Table "B").
 *** Shear walls may not be modified unless structural calculations are submitted and approved by the Building Department.



Building Division

Free-Standing Residential Patio Covers:
Bracing Details

(209) 937-8561

345 N El Dorado St., Stockton CA 95202

Fax (209) 937-8893

8/21/2005

1 OF 1